

VIVID PVC 24V WAVE STATIC

Table of Contents

Specifications	2-4	Snap	8-9
Epistar	2	Swivel	9
Nichia	3	Barrel	10
Technical Specifications	4		
Packaging	4	Mounting Hardware	10-12
Physical Specifications	5	Plastic	10
Part Number Naming	5	Standard	11
		Flexible	11
		Spring Clip	12
		Plastic & Aluminum	12
Connectors	6-10	Testing	13-15
Seamless	6	Certifications	13
Submersible Seamless	7	Fixture Testing	13
		Charts	14-15

Technical Specifications

Light Dimension 0.63 x 0.67in (16x17mm)

Output	Red/Amber	Green/Blue/White	White (CRI90)
LED Light	Epistar SMD LED Chip		
Max Run Length*			
Single Feed	49.21ft (15m)	32.81ft (10m)	32.81ft (10m)
Light Surface	Square profile 160°		
Lumen Maintenance	70,000 Hours L70 @ 25°C : 90,000 L50 @ 25°C		
	50,000 Hours L70 @ 50°C : 70,000 Hours L50 @ 50°C		
Electrical			
Input Voltage	24V DC		
Power Consumption	2.19W/ft (7.2W/m)	3.66W/ft (12W/m)	3.66W/ft (12W/m)
Physical			
LED Count	33 LEDs / ft (108 LEDs/m)		
LED Spacing	0.37in (9.26mm)		
Cutting Unit Length	3.28in (83.3mm) (9 LEDs)	2.19in (55.6mm) (6 LEDs)	2.19in (55.6mm) (6 LEDs)
Thermal Management	Free air convection		
Fixture Connections	End, side & bottom lead wires		
Minimum Bend Diameter	11.81in (300mm) (Side Bending OR Top Bending)		
Temperature Ranges			
Installation	32°F to 113°F (0°C to 45°C)		
Operating	-4°F to 113°F (-20°C to 45°C)		
Humidity	0-95% non condensing		
Dependability			
Warranty	5 Year Limited Warranty		
Safety			
Certification	Tested to UL & CSA by Underwriters Laboratory for use in USA and Canada, complies with California Title 24 Requirements, Lighting Facts. Exceeds ANSI C78.377A, CE & RoHS Compliant.		
IP Rating	IP68 with appropriately rated accessories		

*Max Run Length: Unless otherwise stated, snap and seamless run lengths are the same.

Technical Specifications

Light Dimension 0.63 x 0.67in (16x17mm)

Output	White
LED Light	Nichia SMD LED Chip
Max Run Length*	
Single Feed	32.81ft (10m)
Double Feed	65.62ft (20m)
Light Surface	Square profile 160°
Lumen Maintenance	70,000 Hours L70 @ 25°C : 90,000 L50 @ 25°C 50,000 Hours L70 @ 50°C : 70,000 Hours L50 @ 50°C
Electrical	
Input Voltage	24V DC
Power Consumption	3.66W/ft (12W/m)
Physical	
LED Count	33 LEDs / ft (108 LEDs/m)
LED Spacing	0.37in (9.26mm)
Cutting Unit Length	2.19in (55.6mm) (6 LEDs)
Thermal Management	Free air convection
Fixture Connections	End, side & bottom lead wires
Minimum Bend Diameter	11.81in (300mm) (Side Bending OR Top Bending)
Temperature Ranges	
Installation	32°F to 140°F (0°C to 60°C)
Operating	-13°F to 140°F (-25°C to 60°C)
Humidity	0-95% non condensing
Dependability	
Warranty	5 Year Limited Warranty
Safety	
Certification	Tested to UL & CSA by Underwriters Laboratory for use in USA and Canada, complies with California Title 24 Requirements, Lighting Facts. Exceeds ANSI C78.377A, CE & RoHS Compliant.
IP Rating	IP68 with appropriately rated accessories

*Max Run Length: Unless otherwise stated, snap and seamless run lengths are the same.

Technical Specifications

Epistar

Available Colors

Color	Wavelength/CCT
Red	620-630nm
Green	520-530nm
Blue	465-475nm
Amber	585-595nm
2200K	2238 ± 102K
2500K	2460 ± 120K
2700K (WW)	2725 ± 145K
3000K	3045 ± 175K
3500K (W)	3465 ± 245K
4000K	3985 ± 275K
4500K (CW)	4503 ± 243K
5000K	5029 ± 283K
5700K (DW)	5669 ± 355K

Lumen Count

VB

HB

Color	Per Foot	Per Meter	Per Foot	Per Meter
Red	>39.63lm	>130lm	>39.63lm	>130lm
Green	>91.46lm	>300lm	>91.46lm	>300lm
Blue	>15.24lm	>50lm	>15.24lm	>50lm
Amber	>39.63lm	>130lm	>39.63lm	>130lm
2200K	>128.05lm	>420lm	>121.92lm	>400lm
2500K	>128.05lm	>420lm	>121.92lm	>400lm
2700K	>128.05lm	>420lm	>121.92lm	>400lm
3000K	>128.05lm	>420lm	>121.92lm	>400lm
3500K	>146.3lm	>480lm	>137.2lm	>450lm
4000K	>146.3lm	>480lm	>137.2lm	>450lm
4500K	>146.3lm	>480lm	>137.2lm	>450lm
5000K	>146.3lm	>480lm	>137.2lm	>450lm
5700K	>137.2lm	>450lm	>121.92lm	>400lm

For 2500K, 4500K, 5000K: minimum order quantity of 200 meters.

CRI90

Available Colors

Color	CCT
2200K	2238 ± 102K
2500K	2460 ± 120K
2700K (WW)	2725 ± 145K
3000K	3045 ± 175K
3500K (W)	3465 ± 245K
4000K	3985 ± 275K
4500K (CW)	4503 ± 243K
5000K	5029 ± 283K

Lumen Count

VB & HB

Color	Per Foot	Per Meter	Power
2200K	>97.54lm	>320lm	3.66W/ft (12W/m)
2500K	>97.54lm	>320lm	3.66W/ft (12W/m)
2700K (WW)	>109.73lm	>360lm	3.66W/ft (12W/m)
3000K	>109.73lm	>360lm	3.66W/ft (12W/m)
3500K (W)	>121.92lm	>400lm	3.66W/ft (12W/m)
4000K	>121.92lm	>400lm	3.66W/ft (12W/m)
4500K (CW)	>121.92lm	>400lm	3.66W/ft (12W/m)
5000K	>121.92lm	>400lm	3.66W/ft (12W/m)

For 2200K, 2500K, 4500K, 5000K: Minimum order quantity of 100 meters.

Nichia

Available Colors

Color	CCT Wavelength
2200K	2238 ± 102K
2500K	2460 ± 120K
2700K (WW)	2725 ± 145K
3000K	3045 ± 175K
3500K (W)	3465 ± 245K
4000K	3985 ± 275K
4500K (CW)	4503 ± 243K
5000K	5029 ± 283K

Lumen Count

VB & HB

Color	Per Foot	Per Meter	Power
2200K	>109.73lm	>360lm	3.66W/ft (12W/m)
2500K	>109.73lm	>360lm	3.66W/ft (12W/m)
2700K (WW)	>109.73lm	>360lm	3.66W/ft (12W/m)
3000K	>109.73lm	>360lm	3.66W/ft (12W/m)
3500K (W)	>121.92lm	>400lm	3.66W/ft (12W/m)
4000K	>121.92lm	>400lm	3.66W/ft (12W/m)
4500K (CW)	>121.92lm	>400lm	3.66W/ft (12W/m)
5000K	>121.92lm	>400lm	3.66W/ft (12W/m)

*Color Jackets:

For standard or custom color jacket options, contact your Account Manager. Min. order quantity of 656ft (200m).

Physical Specifications



Bending Direction

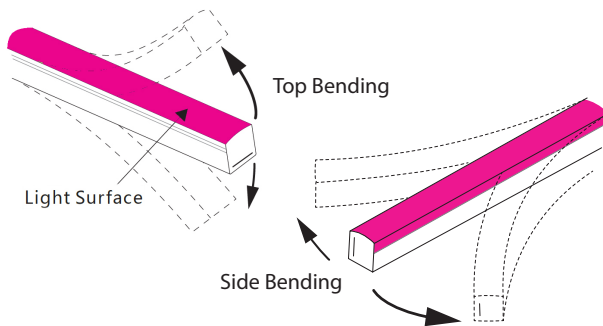

Light Profile

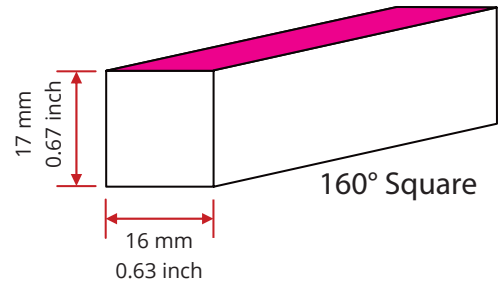

Minimum Bending Diameter

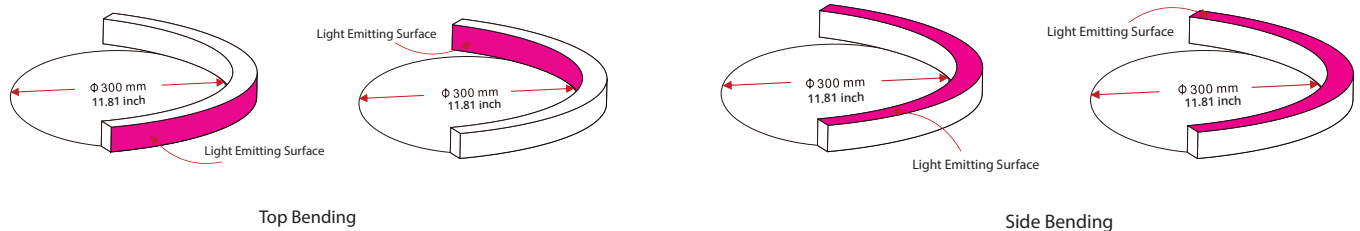

Part Number Naming Convention

NF-16E-X-01-2W-X-XXX-24DC

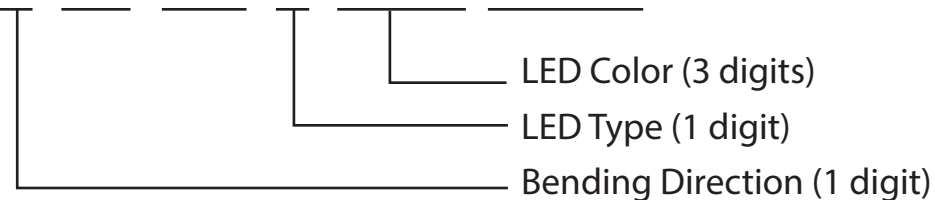

For full part number naming rules, please refer to the document on www.glls.com/support/documentation/

Connectors

Seamless Connectors

IP67: Rated for wet locations, not submersion.
Factory Assembly only.

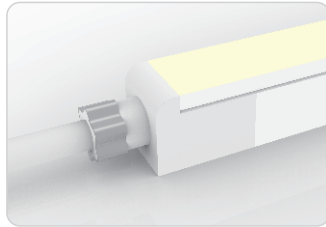

Seamless End Exit

NA-16E-1-00-2W-SE-0-EN-XXX-P

NA-16E-0-00-2W-SE-0-EN-XXX-P

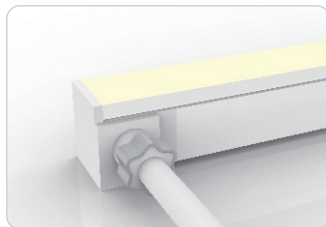
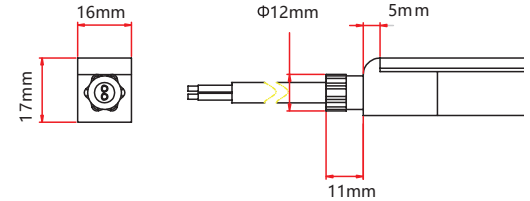

Seamless Side Exit

NA-16E-1-00-2W-SE-1-SR-XXX-P

NA-16E-1-00-2W-SE-2-SL-XXX-P

NA-16E-0-00-XW-SE-1-SL-XXX-P

NA-16E-0-00-XW-SE-2-SL-XXX-P

NA-16E-0-00-XW-SE-1-SR-XXX-P

NA-16E-0-00-XW-SE-2-SR-XXX-P

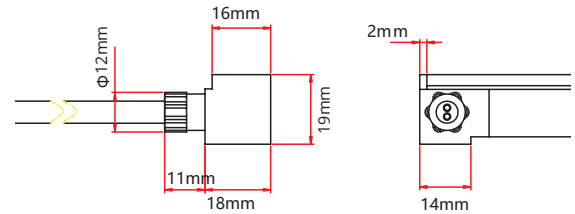

Seamless Bottom Exit

NA-16E-1-00-2W-SE-0-BO-XXX-P

NA-16E-0-00-2W-SE-0-BO-XXX-P

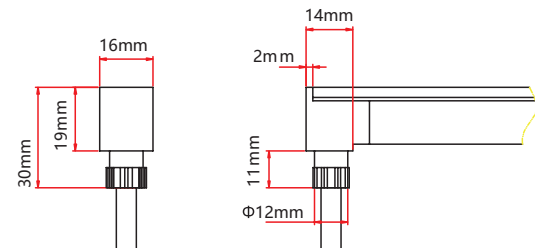

Seamless End Cap

NA-16E-1-00-0W-SE-1-EC-000-P

NA-16E-1-00-0W-SE-2-EC-000-P

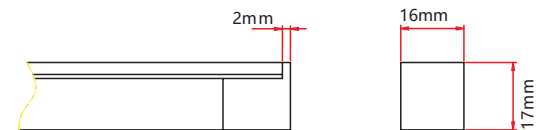

Seamless Jumper

NA-16E-1-00-2W-SE-0-EJ-XXX-P

NA-16E-0-00-2W-SE-0-EJ-XXX-P

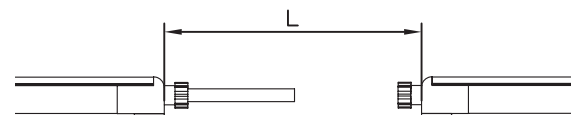

Connectors

IP68: Submersible. Factory Assembly only.
UL&cUL Listed, No-Niche Underwater Luminaires

Submersible Seamless Connectors

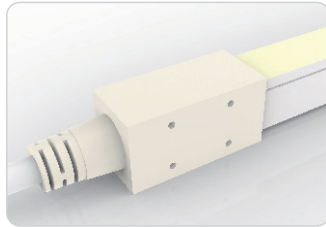

Submersible End Exit

NA-16E-1-00-2W-SU-0-EN-XXX-P

NA-16E-0-00-2W-SU-0-EN-XXX-P

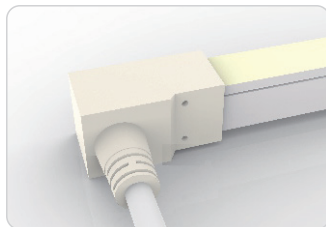
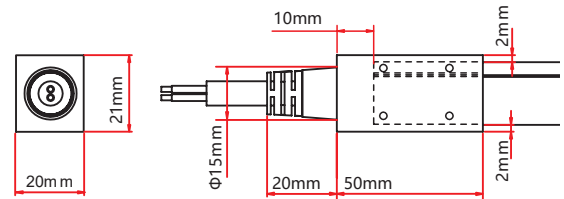

Submersible Side Exit

NA-16E-1-00-2W-SU-2-SL-XXX-P

NA-16E-1-00-2W-SU-1-SR-XXX-P

NA-16E-0-00-2W-SU-1-SL-XXX-P

NA-16E-0-00-2W-SU-2-SL-XXX-P

NA-16E-0-00-2W-SU-1-SR-XXX-P

NA-16E-0-00-2W-SU-2-SR-XXX-P

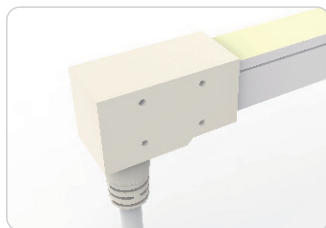
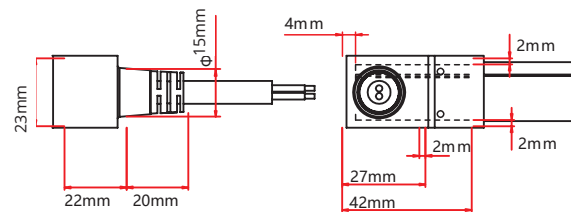

Submersible Bottom Exit

NA-16E-1-00-2W-SU-0-BO-XXX-P

NA-16E-0-00-2W-SU-0-BO-XXX-P

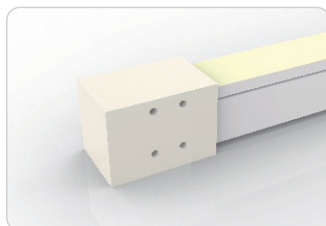
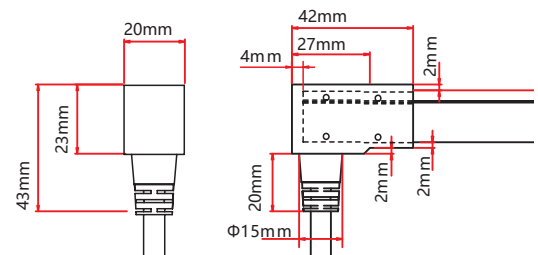

Submersible End Cap

NA-16E-1-00-0W-SU-1-EC-000-P

NA-16E-1-00-0W-SU-2-EC-000-P

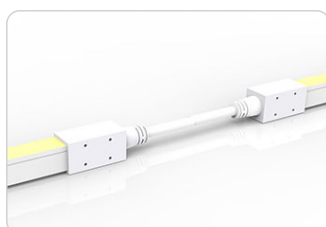
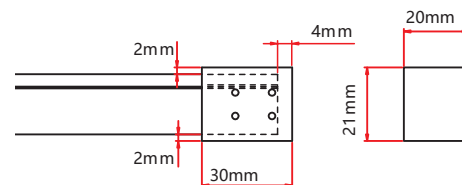

Submersible Jumper

NA-16E-1-00-2W-SU-0-EJ-XXX-P

NA-16E-0-00-2W-SU-0-EJ-XXX-P

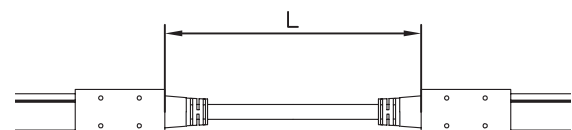

Connectors

Snap Connectors

IP67: Rated for outdoor use.
Factory Assembly or DIY.

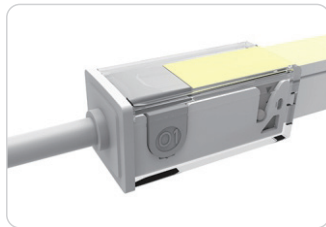

Snap End Exit

NA-16E-1-00-2W-SC-1-EN-XXX-P
NA-16E-1-00-2W-SC-2-EN-XXX-P

NA-16E-0-00-2W-SC-1-BO-XXX-P
NA-16E-0-00-2W-SC-2-BO-XXX-P

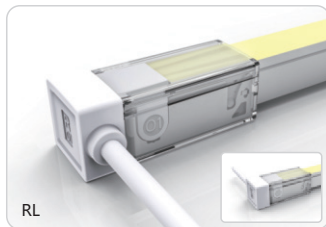
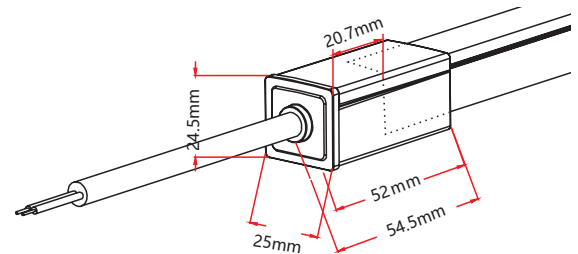

Snap Side Exit

NA-16E-1-00-2W-SC-1-SL-XXX-P
NA-16E-1-00-2W-SC-2-SL-XXX-P
NA-16E-1-00-2W-SC-1-SR-XXX-P
NA-16E-1-00-2W-SC-2-SR-XXX-P

NA-16E-0-00-XW-SC-1-SL-XXX-P
NA-16E-0-00-XW-SC-2-SL-XXX-P
NA-16E-0-00-XW-SC-1-SR-XXX-P
NA-16E-0-00-XW-SC-2-SR-XXX-P

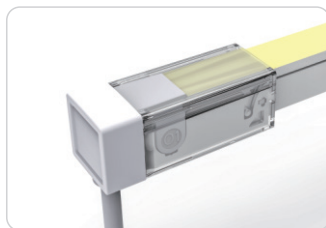
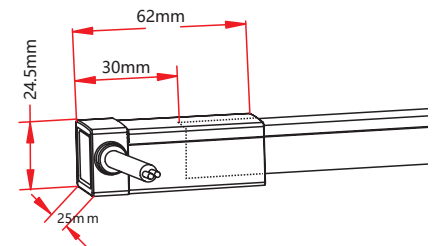

Snap Bottom Exit

NA-16E-1-00-2W-SC-1-BO-XXX-P
NA-16E-1-00-2W-SC-2-BO-XXX-P

NA-16E-0-00-2W-SC-1-BO-XXX-P
NA-16E-0-00-2W-SC-2-BO-XXX-P

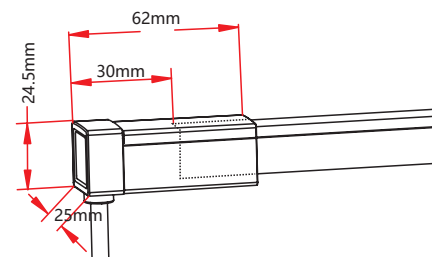

Snap End Cap

NA-16E-1-00-0W-SC-0-EC

NA-16E-0-00-0W-SC-1-EC
NA-16E-0-00-0W-SC-2-EC

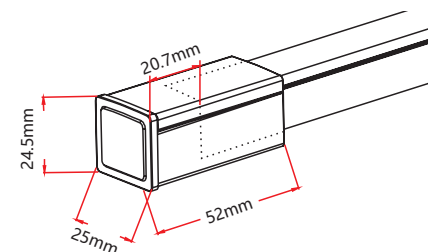

Connectors

IP67: Rated for outdoor use.
Factory Assembly or DIY.

Snap Connectors

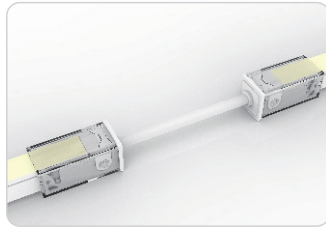

Snap Jumper

NA-16E-1-00-2W-SC-0-EJ-XXX-P

NA-16E-0-00-2W-SC-0-EJ-XXX-P

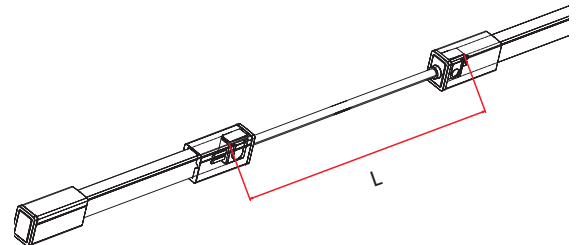

Snap Power T Feed

NA-16E-1-00-2W-SC-0-TF-XXX-P

NA-16E-0-00-2W-SC-0-TF-XXX-P

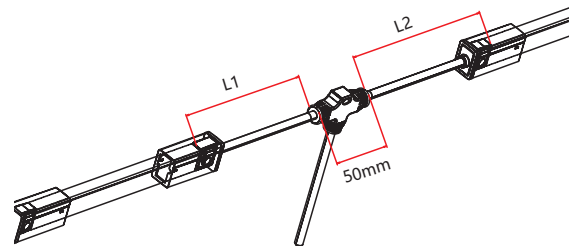

Swivel Connectors

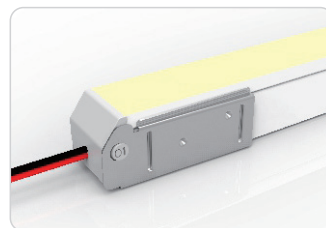

Swivel End Exit

NA-16E-1-00-2W-SV-1-EN-XXX-P

NA-16E-1-00-2W-SV-2-EN-XXX-P

NA-16E-0-00-2W-SV-1-EN-XXX-P

NA-16E-0-00-2W-SV-2-EN-XXX-P

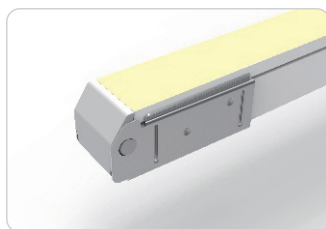
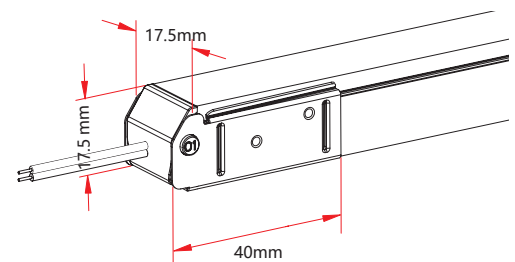

Swivel End Cap

NA-16E-1-00-0W-SW-1-EC-000-P

NA-16E-1-00-0W-SW-2-EC-000-P

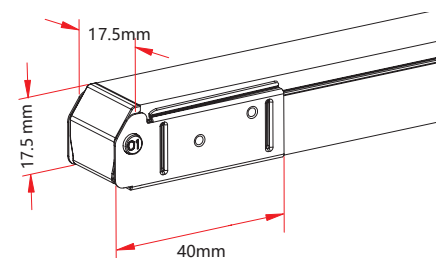

Connectors

IP20: Rated for indoor use only.
Factory Assembly only.

Barrel Connectors



Barrel Connectors

- NA-XX-BC-DC-CXX-F
- NA-XX-BC-DC-CXX-M
- NA-XX-BN-XXA-CXX-F
- NA-XX-BN-XXA-CXX-M
- NA-XX-PL-XXA-CXX-F
- NA-XX-PL-XXA-CXX-M

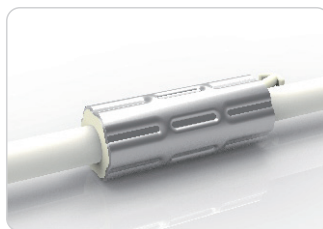
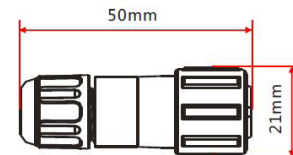

Anti-Wicking Ferrule

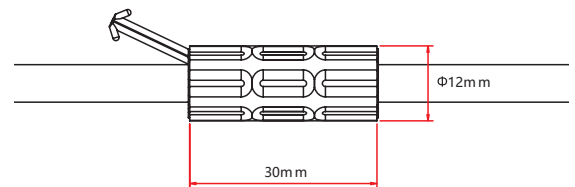

Anvil Cutter

Optional accessory for on-site cutting.

Factory order only

Mounting Hardware Plastic Channel

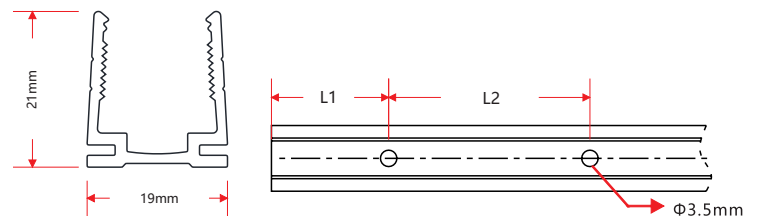

W x H	Standard Length	Part Number	L1	L2	Screw Hole Φ	Hole #
0.75 x 0.83in (19x 21mm)	19.69in (500mm)	CH-16-R-PL-0M5-SD	1.97in (50mm)	7.87in (200mm)	Φ0.14in (3.5mm)	3
	39.37in (1000mm)	CH-16-R-PL-01M-SD	3.94in (100mm)	7.87in (200mm)	Φ0.14in (3.5mm)	5
	78.74in (2000mm)	CH-16-R-PL-02M-SD	3.94in (100mm)	7.87in (200mm)	Φ0.14in (3.5mm)	10

Mounting Hardware

Standard Anodized Aluminum Channel

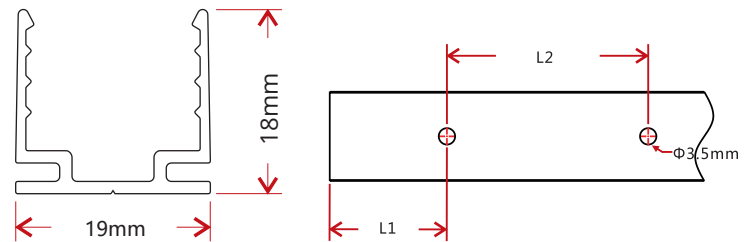
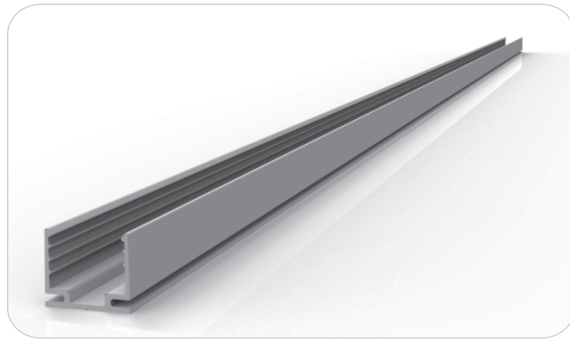

W x H	Standard Length	Part Number	L1	L2	Screw Hole Φ	Hole #
0.75 x 0.71in (19 x 18mm)	1.38in (35mm)	CL-16-R-AL-3C5-SD	0.69in (17.5mm)	/	Φ 0.14in (3.5mm)	1
	19.69in (500mm)	CH-16-R-AL-0M5-SD	1.97in (50mm)	7.87in (200mm)	Φ 0.14in (3.5mm)	3
	39.37in (1000mm)	CH-16-R-AL-01M-SD	3.94in (100mm)	7.87in (200mm)	Φ 0.14in (3.5mm)	5
	78.74in (2000mm)	CH-16-R-AL-02M-SD	3.94in (100mm)	7.87in (200mm)	Φ 0.14in (3.5mm)	10

Stainless Steel Flexible Channel

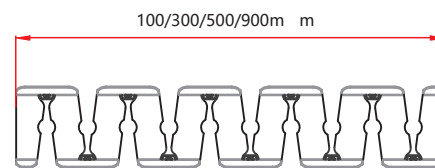
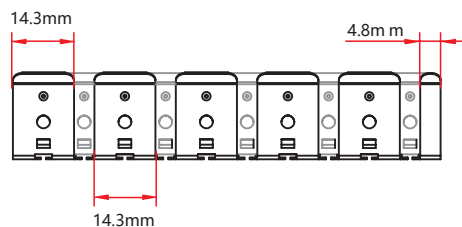
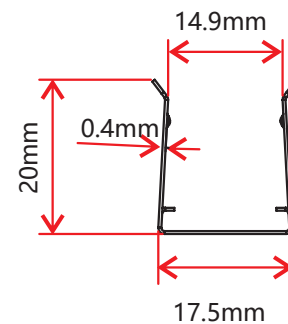
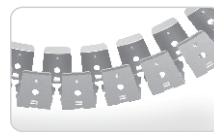
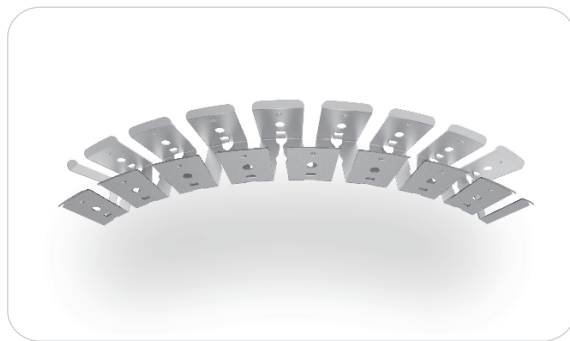

W x H	Standard Length	Part Number
0.69 x 0.79in (17.5 x 20mm)	3.94in (100mm)	CH-16-F-SS-0M1-SD
	11.81in (300mm)	CH-16-F-SS-0M3-SD
	19.69in (500mm)	CH-16-F-SS-0M5-SD
	35.43in (900mm)	CH-16-F-SS-0M9-SD

This profile can be mounted using screws in any gaps where the channel bends.

Mounting Hardware

Spring Clip Anodized Aluminum Channel

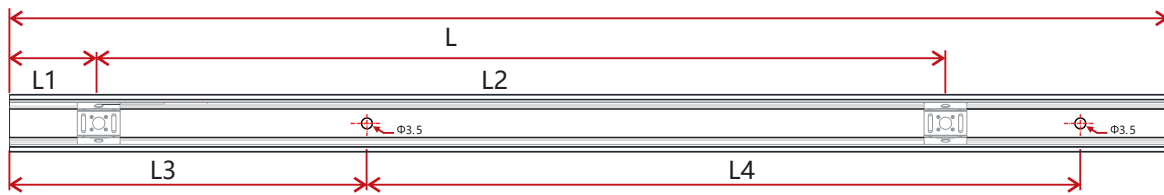
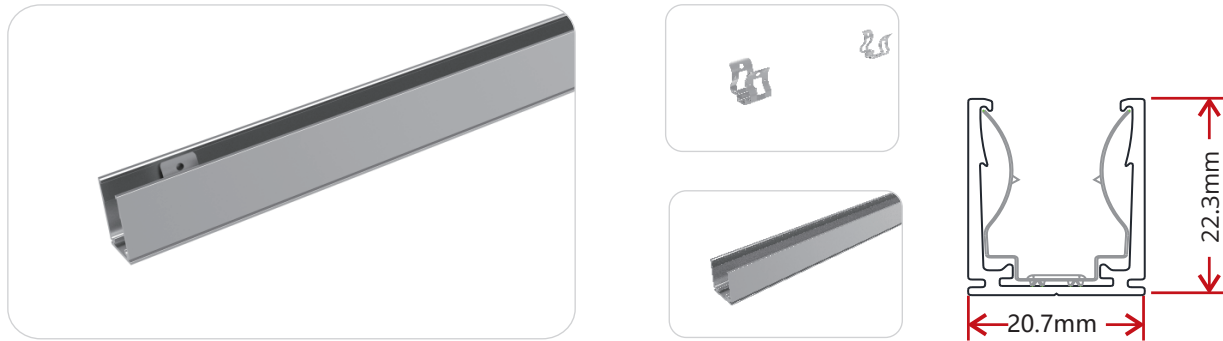

W x H	Standard Length	Part Number	L1	L2	L3	L4	Screw Hole Φ	Hole #	Clip #
0.82 x 0.88in (20.7 x 22.3mm)	1.38in (35mm)	CL-16-R-AL-3C5-SP	0.69in (17.5mm)	/	0.2in (5mm)	0.98in (25mm)	Φ 0.14in (3.5mm)	2	1
	19.69in (500mm)	CH-16-R-AL-0M5-SP	0.98in (25mm)	8.86in (225mm)	1.97in (50mm)	7.87in (200mm)	Φ 0.14in (3.5mm)	3	3
	39.37in (1000mm)	CH-16-R-AL-01M-SP	0.98in (25mm)	9.35in (237.5mm)	3.94in (100mm)	7.87in (200mm)	Φ 0.14in (3.5mm)	5	5
	78.74in (2000mm)	CH-16-R-AL-02M-SP	0.98in (25mm)	9.6in (243.8mm)	3.94in (100mm)	7.87in (200mm)	Φ 0.14in (3.5mm)	10	9

Plastic & Aluminum Channel

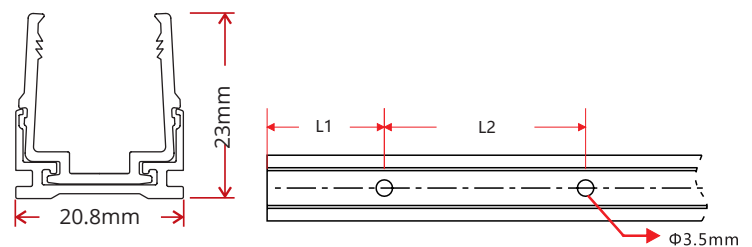
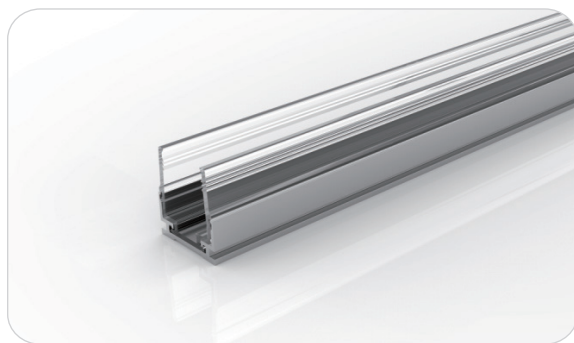

W x H	Standard Length	Part Number	L1	L2	Screw Hole Φ	Hole #
0.82 x 0.91in (20.8x 23mm)	1.38in (35mm)	CL-16-R-AP-3C5-SD	0.69in (17.5mm)	/	Φ 0.14in (3.5mm)	1
	19.69in (500mm)	CH-16-R-AP-0M5-SD	1.97in (50mm)	7.87in (200mm)	Φ 0.14in (3.5mm)	3
	39.37in (1000mm)	CH-16-R-AP-01M-SD	3.94in (100mm)	7.87in (200mm)	Φ 0.14in (3.5mm)	5
	78.74in (2000mm)	CH-16-R-AP-02M-SD	3.94in (100mm)	7.87in (200mm)	Φ 0.14in (3.5mm)	10

Testing

Certifications

	Testing Organization	Certificate Serial N°	Report Reference
UL 2108	UL	20160726-E360029	E360029-2013
CE-EMC	SGS	SZEM1702001259LMV	SZEM160600421302

Fixture Testing

Optical Testing

Spectrum Analysis	IES LM 79 (Lumen, CCT, CRI, XY, SDCM, wavelength)
Photometric Distribution	IES LM 73 (Lumen intensity distribution & Lux diagram)
Lumen Maintenance & Lifetime	IES LM 84 & IES TM28

Temperature Testing

Normal Temperature Test	UL1598 & UL2388 & IEC60598-1 & IEC60598-2-21
Abnormal Operation Test	UL1598 & UL2388 & IEC60598-1 & IEC60598-2-21

Durability Testing

Bending Test	Manufacturer-defined, 500 cycles
Swing Test	UL2388, >750 cycles
Tensile Test	Manufacturer-defined, > the weight of light in max. connection length double feed
Twist Test	Max connection length double feed Manufacturer-defined, >200 cycles
Ball Impact	UL1598 & UL2388 & IEC60598-1 & IEC60598-2-21
IK07 IK08	IEC62262

Environmental Testing

Chlorinated Water Immersion	BG9667, PH6.8-7.6, free chlorine 0.3-0.6mg/L
Salt Water Immersion	IEC60598-1, Salinity 4%
Salt Spray Test	IEC68-2-11
Outdoor Exposure	Manufacturer-defined
Flame Resistance	UL94
UV Exposure	ASTMG 154, ISO 4892-3, UVA @ 340nm
IPX5, IPX6, IPX7, IPX8	IEC60529
Temperature Shock	Manufacturer-defined, -40°C - 60°C (typical temperature range)
Constant Temperature	Manufacturer-defined, 70°C (typical temperature range)

Testing

Charts

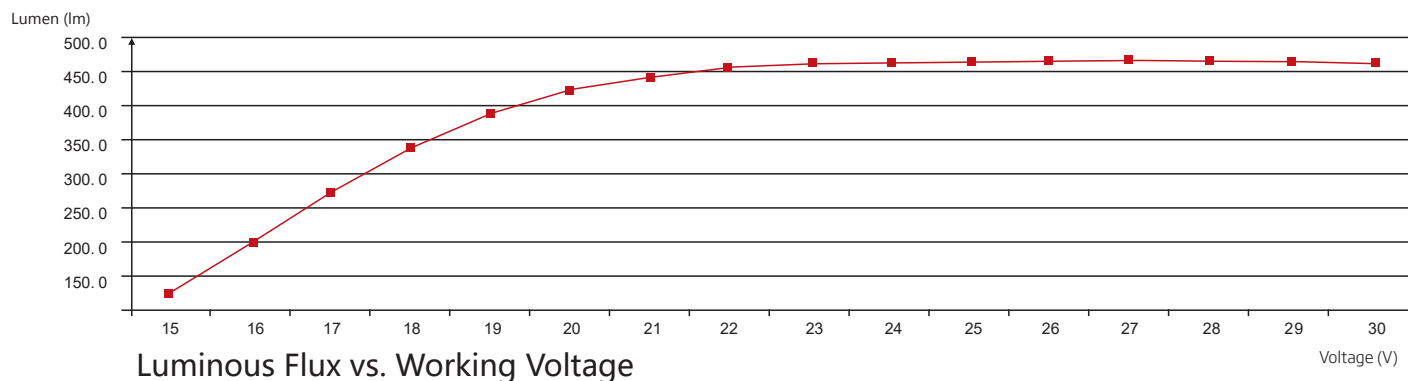
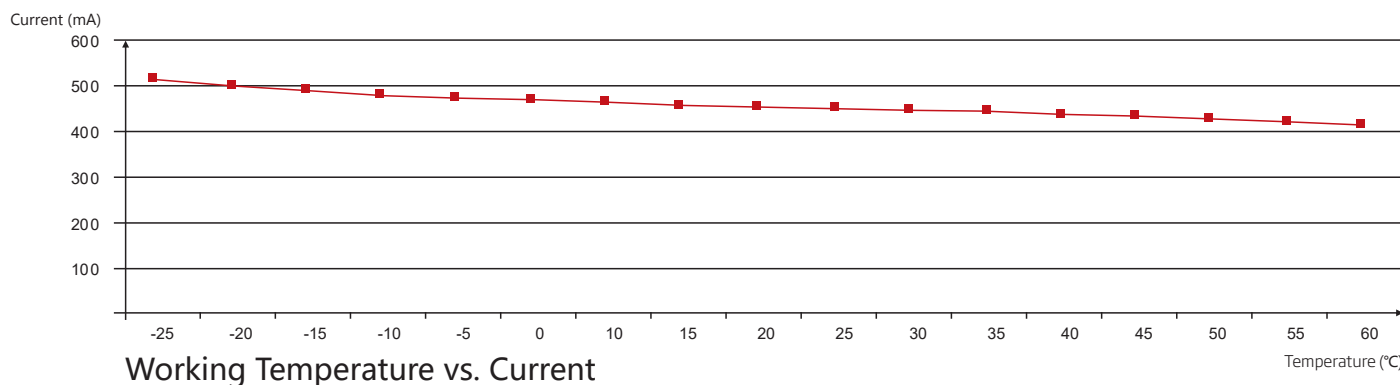

ANSI STANDARD

Nominal CCT Categories

Nominal CCT	Target CCT and tolerance(K)	Target D_{uv}	D_{uv} Tolerance Range
2200K	2238 ±102	0.0000	Tx:CCT of the source
2500K	2460±120	0.0000	For Tx<2870K
2700K	2725 ±145	0.0000	0.000±0.0060
3000K	3045±175	0.0001	For Tx≥2870K
3500K	3465±245	0.0005	$D_{uv}(Tx)±0.0060$
4000K	3985±275	0.0010	where
4500K	4503±243	0.0015	$D_{uv}(Tx)=57700 \times (1/Tx)^2$
5000K	5029±283	0.0020	-44.6 × (1/Tx)
5700K	5667±355	0.0025	+0.00854
6500K	6532±510	0.0031	

Flexible CCT (2200-6500K) $T_F^{1) \pm \Delta T^{2)}$

$D_{uv} T_F^{3)}$

Remark:

- 1) T_F is chosen to be at 100K steps (2300,2400,.....,6400K),excluding the ten nominal CCTs listed in Table 1.
- 2) $\Delta T=1.1900 \times 10^4 \times T^3 - 1.5434 \times 10^4 \times T^2 + 0.7168 \times T - 902.55$
- 3) Same as in the D_{uv} Tolerance Range.

Testing

Charts

(X,Y) Chromaticity Diagram

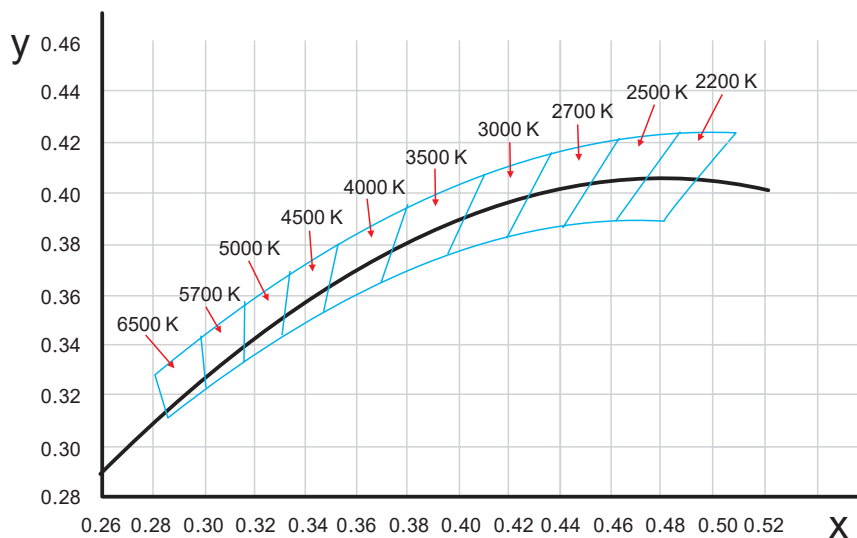

Wavelength of Color Light

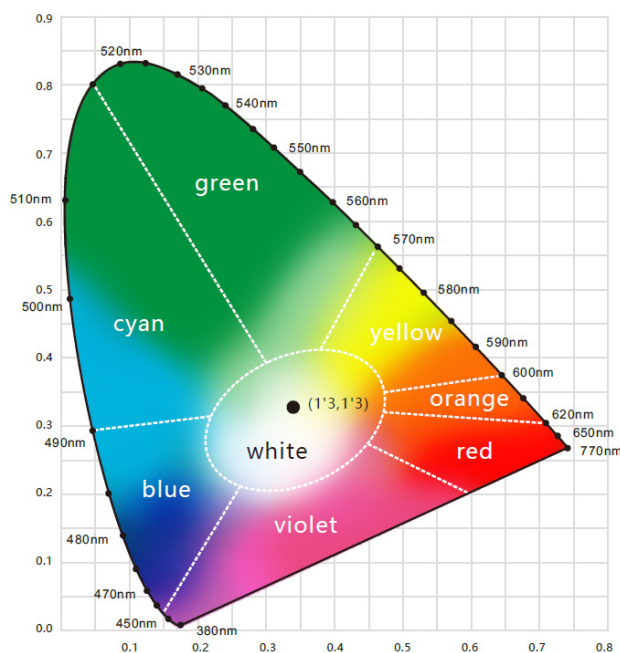

Light Color

